

JUNIOR

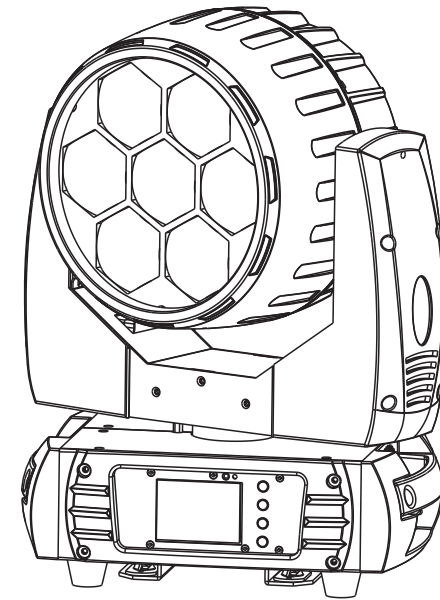

PR LIGHTING LTD.
<http://www.pr-lighting.com>
1582 Xingye Avenue, Nancun Panyu
Guangzhou, 511442 China
TEL: +86-20-3995 2888

JNR MINI MANTIS 7*40
JNR-8133

1 SAFETY INSTRUCTIONS



CAUTION

Be careful with your operations. With a dangerous voltage you can suffer a dangerous electric shock when touching wires!

This device has left the factory in perfect condition. In order to maintain this condition and to ensure a safe operation, it is absolutely necessary for the user to follow the safety instructions and warning notes written in this user manual.



IMPORTANT

Damages caused by the disregard of this user manual are not subject to warranty. The dealer will not accept liability for any resulting defects or problems.

If the device has been exposed to temperature changes due to environmental changes, do not switch it on immediately. The arising condensation could damage the device. Leave the device switched off until it has reached room temperature.

This device falls under protection-class I. Therefore it is essential that the device be earthed.

The electric connection must carry out by qualified person.

The device shall only be used with rated voltage and frequency.

Make sure that the available voltage is not higher than stated at the end of this manual.

Make sure the power cord is never crimped or damaged by sharp edges. If this would be the case, replacement of the cable must be done by an authorized dealer.

Always disconnect from the mains, when the device is not in use or before cleaning it. Only handle the power cord by the plug. Never pull out the plug by tugging the power cord.

During initial start-up some smoke or smell may arise. This is a normal process and does not necessarily mean that the device is defective, it should decrease gradually.

Please don't project the beam onto combustible substances.

Fixtures cannot be installed on combustible substances, keep more than 50cm distance with wall for smooth air flow, so there should be no shelter for fans and ventilation for heat radiation.

If the external flexible cable or cord of this luminaire is damaged, it shall be exclusively replaced by the manufacturer or his service agent or a similar qualified person in order to avoid a hazard.

10 MAINTENANCE AND CLEANING

The following points have to be considered during the inspection:

- 1) All screws for installing the devices or parts of the device have to be tightly connected and must not be corroded.
- 2) There must not be any deformations on the housing, color lenses, fixations and installation spots (ceiling, suspension, trussing).
- 3) Mechanically moved parts must not show any traces of wearing and must not rotate with unbalances.
- 4) The electric power supply cables must not show any damage, material fatigue or sediments.

Further instructions depending on the installation spot and usage have to be adhered by a skilled installer and any safety problems have to be removed.



CAUTION

Disconnect from mains before starting maintenance operations.



In order to make the lights in good condition and extend the life time, we suggest a regular cleaning to the lights.

- 1) Clean the inside and outside lens each week to avoid the weakness of the lights due to accumulation of dust.
- 2) Clean the fan each week.
- 3) A detailed electric check by approved electrical engineer each three months, make sure that the circuit contacts are in good condition, prevent the poor contact of circuit from overheating.

We recommend a frequent cleaning of the device. Please use a moist, lint-free cloth. Never use alcohol or solvents.

There are no serviceable parts inside the device. Please refer to the instructions under "Installation instructions".

Should you need any spare parts, please order genuine parts from your local dealer.

26		Blue in Pixel 3	0-255	Blue in pixel 3 saturation control(0-100%)
27		White in Pixel 3	0-255	White in pixel 3 saturation control(0-100%)
28		Red in Pixel 4	0-255	Red in pixel 4 saturation control(0-100%)
29		Green in Pixel 4	0-255	Green in pixel 4 saturation control(0-100%)
30		Blue in Pixel 4	0-255	Blue in pixel 4 saturation control(0-100%)
31		White in Pixel 4	0-255	White in pixel 4 saturation control(0-100%)
32		Red in Pixel 5	0-255	Red in pixel 5 saturation control(0-100%)
33		Green in Pixel 5	0-255	Green in pixel 5 saturation control(0-100%)
34		Blue in Pixel 5	0-255	Blue in pixel 5 saturation control(0-100%)
35		White in Pixel 5	0-255	White in pixel 5 saturation control(0-100%)
36		Red in Pixel 6	0-255	Red in pixel 6 saturation control(0-100%)
37		Green in Pixel 6	0-255	Green in pixel 6 saturation control(0-100%)
38		Blue in Pixel 6	0-255	Blue in pixel 6 saturation control(0-100%)
39		White in Pixel 6	0-255	White in pixel 6 saturation control(0-100%)
40		Red in Pixel 7	0-255	Red in pixel 7 saturation control(0-100%)
41		Green in Pixel 7	0-255	Green in pixel 7 saturation control(0-100%)
42		Blue in Pixel 7	0-255	Blue in pixel 7 saturation control(0-100%)
43		White in Pixel 7	0-255	White in pixel 7 saturation control(0-100%)
44	20	14	0-19	No function
			20-29	No function
			30-39	No function
			40-79	No function
			80-89	All motor reset
			90-94	Scan motor reset
			95-99	Focus motor reset
			100-119	Internal program 1
			120-139	Internal program 2
			140-159	Internal program 3
			160-179	Internal program 4
			180-199	Internal program 5
			200-219	Internal program 6
			220-239	Internal program 7
240-255	Internal sound program 1			

2 UNPACKING

Thank you for choosing our JNR MINI MANTIS 7*40. For your own safety, please read this manual before installing the device. This manual covers the important information on installation and applications. Please install and operate the fixture with following instructions. Meanwhile, please keep this manual well for future needs.

The JNR MINI MANTIS 7*40 is made of a new type of high temperature strength of engineering plastics and cast aluminum casing with nice outlook. The fixture is designed and manufactured strictly following CE standards, complying with international standard DMX512 protocol. It's available independently controlled and linkable with each other for operation. And it is applicable for large-scale live performances, theater, studio, nightclubs and discos.

The JNR MINI MANTIS 7*40 adopts 7PCS 4-IN-1 40W LEDs which features high brightness and stability. Please carefully unpack it when you receive the fixture and check whether it is damaged during the transportation. And please check whether the following items are included inside the box:

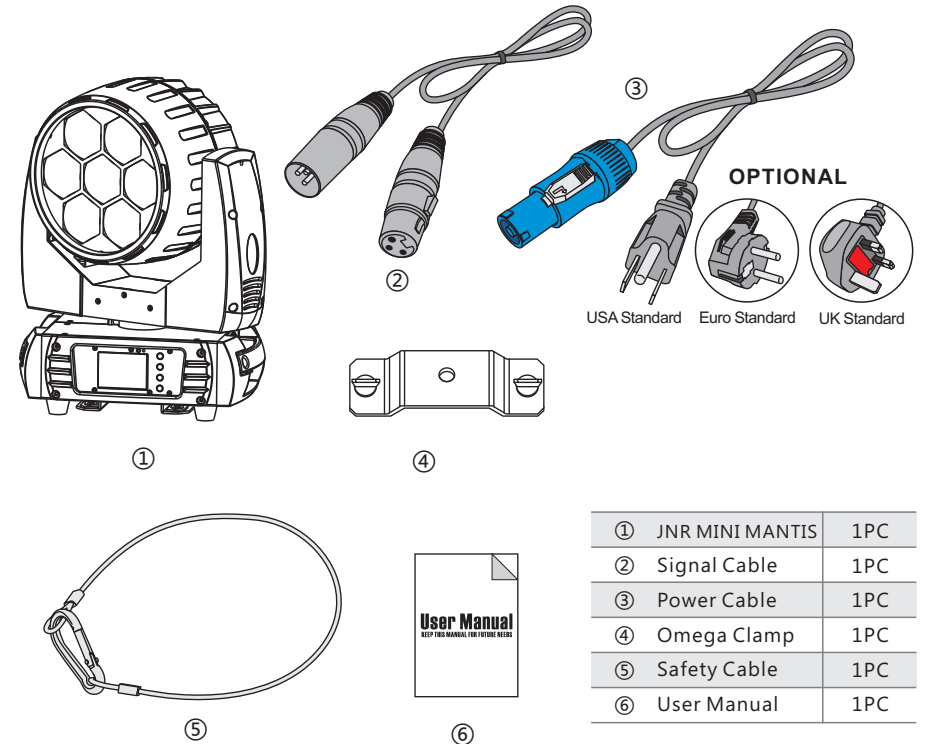

①	JNR MINI MANTIS	1PC
②	Signal Cable	1PC
③	Power Cable	1PC
④	Omega Clamp	1PC
⑤	Safety Cable	1PC
⑥	User Manual	1PC

3 FEATURES & SPECIFICATIONS

Features

- 7*40W 4-IN-1 OSRAM RGBW LEDs
- 50,000 hours lifespan and low power consumption
- Pixel mapping capability with each LEDs controllable individually
- Specific optic lens of highly efficient elements integrated with glass tube
- Fast, smooth and quiet motorized zoom with 8° -62° range
- Even, soft edge and pure color mixing coverage
- Flicker free sources management
- 8/16 Bit smooth, fast and precise PAN/TILT movement
- 630°/540°/360° PAN optional and 270°/180°/90° TILT optional
- PAN/TILT reversible advantage
- PAN/TILT calibration available
- Scan position memory, auto reposition after unexpected movement
- 0-100% Smooth linear LED dimmer
- 7 built-in default programs for easy operation
- 6 Kinds of pre-programmed macro effects with variable speed
- Variable speed strobe effect with 1-25 flashes per second
- Variable pulse and random effects
- 44/20/14 DMX channel modes (USITT DMX-512)
- DMX512, master-slave and sound activated controllable or auto operation
- Sound control with sensitivity adjustment
- 2.4" TFT LCD display (320*240pix) with 4 control buttons
- LCD display switch-off automatically after 60 seconds
- 180° Reversible for LCD display
- DMX signal monitoring indicator available
- Lower noise and efficient FAN cooling system
- Efficient low noise self adjusting fan cooling system
- Constant temperature readout and management function
- Over heat protection management
- Powercon IN/OUT with power switch and fuse
- 3-Pin DMX connectors IN/OUT
- DB rating@1M=54.18dB
- IP20 protection rating
- -35°C to 45°C ambient temperature
- 1*1/4 turn fastening Omega Clamps (Adaptable vertically and horizontally)
- 1*Safety attachment point
- CE (EMC/LVD) and RoHS certified

15	19	Static patterns (If channel 18 is in the interval 016-031)	32-39	Static scene 5	
			40-47	Static scene 6	
			48-55	Static scene 7	
			56-63	Static scene 8	
			64-71	Static scene 9	
			72-79	Static scene 10	
			80-87	Static scene 11	
			88-95	Static scene 12	
			96-103	Static scene 13	
			104-111	Static scene 14	
			112-119	Static scene 15	
			120-127	Static scene 16	
			128-135	Static scene 17	
			136-143	Static scene 18	
			144-151	Static scene 19	
			152-159	Static scene 20	
			160-167	Static scene 21	
			168-175	Static scene 22	
			176-183	Static scene 23	
			184-191	Static scene 24	
			192-199	Static scene 25	
			200-207	Static scene 26	
			208-215	Static scene 27	
			216-223	Static scene 28	
			224-231	Static scene 29	
			232-239	Static scene 30	
			240-247	Static scene 31	
			248-255	Static scene 32	
			Dynamic Patterns (If channel 18 is in the interval 032-255)	0-23	No function
				24-137	Forward speed from zero speed to fast speed
				138-141	Stop movement
				142-255	Reverse speed from zero speed to fast speed
		16		Red in Pixel 1	0-255
17		Green in Pixel 1	0-255	Green in pixel 1 saturation control(0-100%)	
18		Blue in Pixel 1	0-255	Blue in pixel 1 saturation control(0-100%)	
19		White in Pixel 1	0-255	White in pixel 1 saturation control(0-100%)	
20		Red in Pixel 2	0-255	Red in pixel 2 saturation control(0-100%)	
21		Green in Pixel 2	0-255	Green in pixel 2 saturation control(0-100%)	
22		Blue in Pixel 2	0-255	Blue in pixel 2 saturation control(0-100%)	
23		White in Pixel 2	0-255	White in pixel 2 saturation control(0-100%)	
24		Red in Pixel 3	0-255	Red in pixel 3 saturation control(0-100%)	
25		Green in Pixel 3	0-255	Green in pixel 3 saturation control(0-100%)	

				226-240	Gradual nuance from full white 3200k to white 4200k
				241-255	Gradual nuance from full white 4200k to white 5600k
13	17		Background dimmer	0-255	Background dimmer 0-100%
14	18		Patterns	0-15	No function
				16-31	Static patterns
				32-38	Dynamic scene 1
				39-45	Dynamic scene 2
				46-52	Dynamic scene 3
				53-59	Dynamic scene 4
				60-66	Dynamic scene 5
				67-73	Dynamic scene 6
				74-80	Dynamic scene 7
				81-87	Dynamic scene 8
				88-94	Dynamic scene 9
				95-101	Dynamic scene 10
				102-108	Dynamic scene 11
				109-115	Dynamic scene 12
				116-122	Dynamic scene 13
				123-129	Dynamic scene 14
				130-136	Dynamic scene 15
				137-143	Dynamic scene 16
				144-150	Dynamic scene 17
				151-157	Dynamic scene 18
				158-164	Dynamic scene 19
				165-171	Dynamic scene 20
				172-178	Dynamic scene 21
				179-185	Dynamic scene 22
				186-192	Dynamic scene 23
				193-199	Dynamic scene 24
				200-206	Dynamic scene 25
				207-213	Dynamic scene 26
				214-220	Dynamic scene 27
				221-227	Dynamic scene 28
				228-234	Dynamic scene 29
				235-241	Dynamic scene 30
242-248	Dynamic scene 31				
249-255	Dynamic scene 32				
15	19		Static patterns or patterns speed	0-7	Static scene 1
				8-15	Static scene 2
				16-23	Static scene 3
				24-31	Static scene 4

Specifications

Input Voltage: AC90-260V 50/60Hz

LED Quantities: 7*40W 4-IN-1 LED(RGBW)LEDs

Control Signal: DMX512, master-slave and sound activated or auto operation

Control Channel: 44/20/14 DMX Channels USITT DMX-512

Power Consumption: 345W

Dimensions: 327(D)*198(W)*397(H)mm

Packing Dimensions: 410(D)*305(W)*473(H)mm

Net Weight: 9.2kg

Gross Weight: 12kg

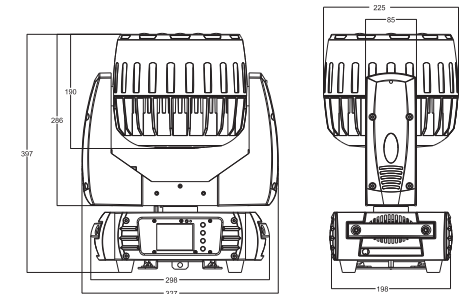

4 PHOTOMETRIC DATA

Photometric Beam Angle Data $8^\circ \sim 62^\circ$ Beam Angle $LUX \times 0.0929 = FC$

	2641 / 28435	400 / 4281	160 / 1727	18 / 198	
R	485 / 5220	75 / 805	22 / 233	14 / 148	
G	1953 / 21021	280 / 3300	114 / 1232	523 / 480	
B	3796 / 40865	600 / 6387	220 / 2365	100 / 1065	
	782 / 8415	103 / 1113	36 / 385	19 / 201	
W	3474 / 37400	560 / 6031	203 / 2183	94 / 1012	
	746 / 8030	94 / 1013	33 / 352	11 / 118	
RGBW	11343 / 122100	1770 / 19052	680 / 7315	348 / 3751	(8°)
	2231 / 24013	270 / 3000	114 / 1221	62 / 663	(62°) (FC/LUX)

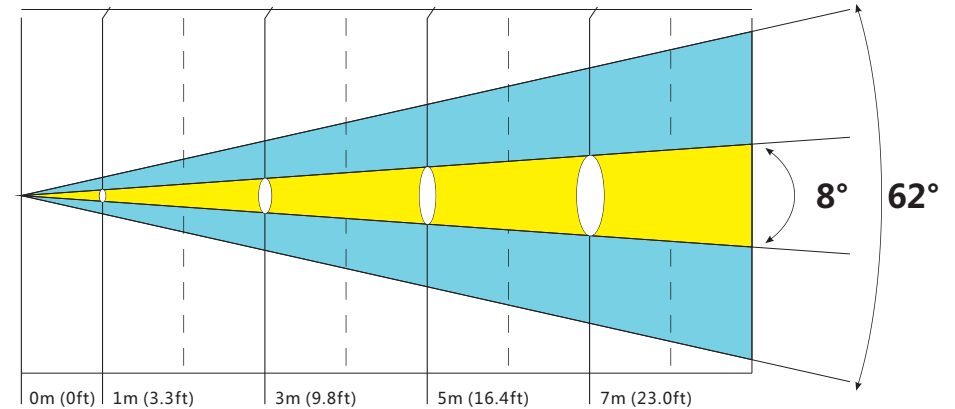

5 OPERATION INSTRUCTIONS

- The JNR MINI MANTIS 7*40 is for wash effect for on-site decoration purpose.
- Don't turn on the fixture if it's been through severe temperature difference like after transportation because it might damage the light due to the environment changes. So make sure to operate the fixture until it is in normal temperature.
- This light should be keep away from strong shaking during any transportation or movement.
- Don't pull up the light by only the head, or it might cause damages to the mechanical parts.
- Don't expose the fixture in overheat, moisture or environment with too much dust when installing it. And don't lay any power cables on the floor. Or it might cause electronic shock to the people.
- Make sure the installation place is in good safety condition before installing the fixture.
- Make sure to put the safety chain and check whether the screws are screwed properly when installing the fixture.
- Make sure the lens are in good condition. It's recommended to replace the units if there are any damages or severe scratch.
- Make sure the fixture is operated by qualified personnel who knows the fixture before using.
- Keep the original packages if any second shipment is needed.
- Don't try to change the fixtures without any instruction by the manufacturer or the appointed repairing agencies.
- It is not in warranty range if there are any malfunctions from not following the user manual to operate or any illegal operation, like shock short circuit, electronic shock, lamp broke, etc.

6 INSTALLATIONS

Cautions: For added protection mount the fixtures in areas outside walking paths, seating areas, or in areas were the fixture might be reached by unauthorized personnel.

Before mounting the fixture to any surface, make sure that the installation area can hold a minimum point load of 10 times the device's weight.

Fixture installation must always be secured with a secondary safety attachment, such as an appropriate safety cable.

				226-240	Gradual nuance from full white 3200k to white 4200k
				241-255	Gradual nuance from full white 4200k to white 5600k
10	14		Foreground color for patterns	0-0	No function
				1-13	Red
				14-27	Green
				28-41	Blue
				42-55	White
				56-69	Red+White
				70-83	Green+White
				84-97	Blue+White
				98-111	Green+Blue
				112-125	Red+Blue
				126-139	Red+Green
				140-153	Green+Blue + White
				154-167	Red+Blue+white
				168-181	Red + Green + Blue
				182-195	Red + Green + Blue + White
11	15		Foreground dimmer	0-255	Foreground dimmer0-100%
12	16	11	Background color for patterns	0-0	No function
				1-13	Red
				14-27	Green
				28-41	Blue
				42-55	White
				56-69	Red+White
				70-83	Green+White
				84-97	Blue+White
				98-111	Green+Blue
				112-125	Red+Blue
				126-139	Red+Green
				140-153	Green+Blue + White
				154-167	Red+Blue+white
				168-181	Red + Green + Blue
				182-195	Red + Green + Blue + White
				196-225	Gradual nuance from full white to white 3200k
				226-240	Gradual nuance from full white 3200k to white 4200k
				241-255	Gradual nuance from full white 4200k to white 5600k

9 DMX CHANNELS

Mode/Channel			Function	Values	Description
44	20	14			
1	1	1	PAN	0-255	PAN movement
2	2	2	PAN-fine	0-255	Fine control of PAN movement
3	3	3	TILT	0-255	TILT movement
4	4	4	TILT-fine	0-225	Fine control of TILT movement
5	5	5	Speed PAN/TILT	0-225	Max to min speed
				226-235	Blackout by movement
				236-255	No function
6	6	6	Dimmer	0-255	Dimmer 0%...100%
7	7	7	Shutter	0-31	Shutter closed
				32-63	Shutter open
				64-95	Strobe effect slow to fast
				96-127	Shutter open
				128-159	Pulse-effect in sequences slow to fast
				160-191	Shutter open
	8	8	Red	0-255	0-100%Red dimmer from dark to bright
	9	9	Green	0-255	0-100%Green dimmer from dark to bright
	10	10	Blue	0-255	0-100%Blue dimmer from dark to bright
	11	11	White	0-255	0-100%White dimmer from dark to bright
8	12	12	Zoom	0-225	In(near)to out (far)
9	13	13	Virtual color	0-0	No function
				1-13	Red
				14-27	Green
				28-41	Blue
				42-55	White
				56-69	Red+White
				70-83	Green+White
				84-97	Blue+White
				98-111	Green+Blue
				112-125	Red+Blue
				126-139	Red+Green
				140-153	Green+Blue + White
				154-167	Red+Blue+white
				168-181	Red + Green + Blue
				182-195	Red + Green + Blue + White
				196-225	Gradual nuance from full white to white 3200k

Never stand directly below the device when mounting, removing, or servicing the fixture.

from a ceiling, or set on a flat level surface (see illustration below). Be sure this fixture is kept at least 0.5m (1.5 ft) away from any flammable materials (decoration etc.).

Always use and install the supplied safety cable as a safety measure to prevent accidental damage and/or injury in the event the clamp fails.

Mounting points: Overhead mounting requires extensive experience, including amongst others calculating working load limits, a fine knowledge of the installation material being used, and periodic safety inspection of all installation material and the fixture. If you lack these qualifications, do not attempt the installation yourself. Improper installation can result in bodily injury.

Be sure to complete all rigging and installation procedures before connecting the main power cord to the appropriate wall outlet.

Clamp mounting: The JNR MINI MANTIS 7*40 provides a unique mounting bracket assembly that integrates the bottom of the base, and the safety cable rigging point in one unit (see the illustration below). When mounting this fixture to truss be sure to secure an appropriately rated clamp to the included omega bracket using a M10 screw fitted through the center hole of the "omega bracket". As an added safety measure be sure to attached at least one properly rated safety cable to the fixture using on of the safety cable rigging point integrated in the base assembly.

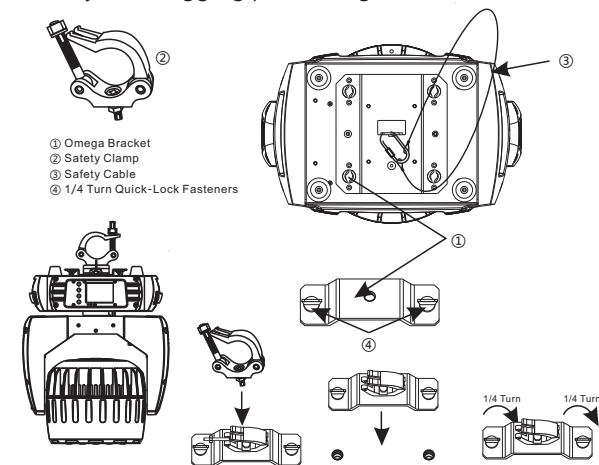

Regardless of the rigging option you choose for your JNR MINI MANTIS 7*40, always be sure to secure your fixture with a safety cable. The fixture provides a built-in rigging point for a safety cable on the hanging bracket as illustrated above. Be sure to only use the designated rigging point for the safety cable and never secure a safety cable to a carrying handle.

7 DMX-512 CONTROL CONNECTIONS

Connect the provided XLR cable to the female 3-pin XLR output of your controller and the other side to the male 3-pin XLR input of the moving head. You can chain multiple

Moving head together through serial linking. The cable needed should be two core, screened cable with XLR input and output connectors. Please refer to the diagram below.

DMX-512 connection with DMX terminator

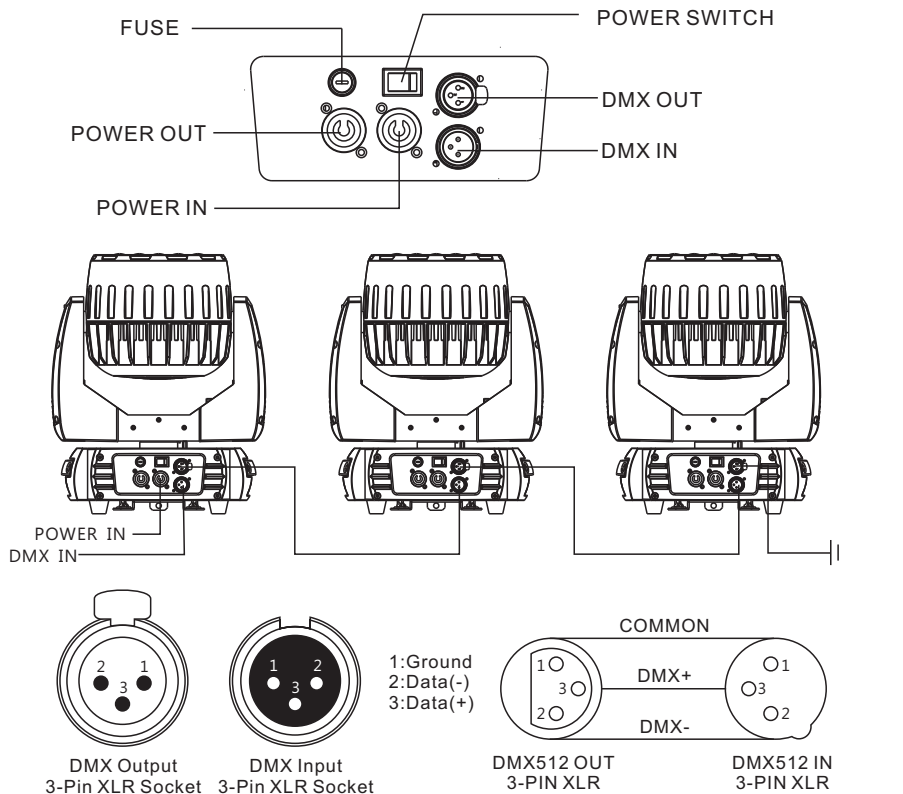

For installations where the DMX cable has to run a long distance or is in an electrically noisy environment, such as in a discotheque, it is recommended to use a DMX terminator. This helps in preventing corruption of the digital control signal by electrical noise. The DMX terminator is simply an XLR plug with a 120 Ω resistor connected between pins 2 and 3, which is then plugged into the output XLR socket of the last fixture in the chain. Please see illustrations below.

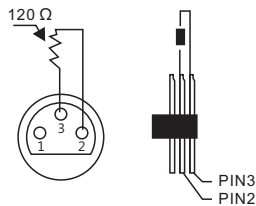

8 MENU OPERATIONS

Function Mode	DMX address	A001-AXXX		DMX address setting
	Channel mode	CH44		
Ch20				20 channel mode
CH14				14 channel mode
Auto run	Internal program 1~8	Master/Alone	Alone mode	
Music control	Internal program 1~8	Master/Alone	Sound mode	
Option	Reset default	Yes/No		Over loading factory all parameters
	Signal set	Wire DMX		Wire DMX input
		Wireless DMX		Wireless DMX input
		Act WDMX & Out		Wireless DMX input, wire DMX output signal at the same time
	PAN/TILT	Reverse PAN (On/Off)		PAN scan reverse
		Reverse TILT (On/Off)		TILT scan reverse
		Select PAN 630°/540° /360°		PAN angle select
		Select TILT 270°/180°/90°		TILT angle select
	UI SET	Mic sensitivity 0~99%		Mic sensitivity setting
		OFF signal mode (On/Off)		No DMX signal,keep the original State(No)reset state
Information	Temperature	XXX°C/°F		Current temperature
	Software version	V1.0~v9.9		Software version
Manual Control	Reset	Total reset		Reset all
		PAN/TILT reset		PAN/TILT reset
		Zoom reset		Zoom reset
	Channel	PAN=XXX.....		Channel value control
ADVANCED (Access Code 088)	Calibration	PAN=XXX.....		Calibration function

Tip : Press UP& DOWN buttons at same time , hold on 3 seconds , Display rotating

